

Design of Automatic Measuring Machine of Mass and Dimension with the DFMA Method

Dodi Sofyan Arief^a, Minarni^b, Adhy Prayitno^a, M Dalil^a, Aulia Rahman^a, and Syahru Ramadonal^a

^{a)} *Department of Mechanical Engineering, Faculty of Engineering, Universitas Riau, Indonesia*

^{b)} *Department of Physics, Faculty of Mathematics and Natural Sciences, Universitas Riau, Indonesia*

*Corresponding author: dodidarul@yahoo.com

Paper History

Received: 15-September-2018

Received in revised form: 25-September-2018

Accepted: 4-October-2018

ABSTRACT

The design is the initial activity of a series of product manufacturing processes. The design is considered one of the most important parts to produce a complete and comprehensive manufacturing product. The ability to design and then realize in real products is an advantage, both for designers and manufacturing industries that produce the design of Automatic measuring machine of mass and dimension is a machine that can take information in the form of mass and dimensions of an object in the usual form. This machine is the development of a device called Machine Vision. Machine vision is a machine consisting of hardware and software. This is set to be able to retrieve information from digital images or images automatically, which is used for quality control. Machine vision is very dependent on sensors and cameras. Laser light is used as a sensor which has the task of mapping measurement objects while the camera serves to capture light waves produced by lasers on measuring objects so that the camera takes pictures to take dimensional data from the measuring object in a one-meter unit. The development of machine vision in question is the addition of a mass meter to this system. Mass measuring instrument using a digital weigher in the form of a load cell. A load cell is a sensor designed to detect the pressure or weight of a load, measurements made by load cells use the principle of pressure. The working principle of an automatic measuring machine of mass and dimensions is a measurement object that is placed at the base of the object where the load cell is placed to obtain mass data, along with the laser source and the camera move together for dimensional data

retrieval. After getting all the desired data, the measured measurement object is moved to a storage area with a previously designed driving system.

KEY WORDS: *Design, Automatic Measuring Machine, DFMA.*

1.0 INTRODUCTION

The development of technology in the digital era as it is now has become more intensive and advanced. So many advanced technologies that have been created by humans, for example in the field of information technology in the form of smart phones (gadgets) that are increasingly developing and increasingly sophisticated over time, coupled with increasing purchasing power, it is no wonder that today's gadgets are a necessity for human. This is very influential and gives very big changes in human life in various fields, for example in the buying and selling system that is done online which is considered more practical and time-saving. The rise of sales made online is inevitably requiring the provider (shipping service) to send goods from the seller to consumers who have bought in the buying and selling system carried out.

Goods shipping services in Indonesia are a growing business because the longer the competition will increase. Currently courier services and logistic entrepreneurs are competing to offer courier services, one of the obstacles that must be faced in courier and logistics services is in terms of variations in the shipment. With variations in goods that are increasing, both in size and type of material, the system for determining shipping rates also experiences variations.

In general, the process of shipping goods in Indonesia is done traditionally, starting from the receipt of goods from consumers, packaging that is in accordance with the standard to measuring the weight and volume of goods to obtain rates of shipping. Payments are made by calculating the weight of the quantity in kg and the volume quantity in units of m³ (Respatindo, 2012). For

goods that have light mass and large volumes, the rates for goods are subject to a volumetric calculation formula with ($V = \text{length} \times \text{width} \times \text{height}$ divided by 6000), the volumetric calculation multiplied by the rates per kg according to the destination (Irviyanti Ganis, 2010). Therefore, goods shipping company in Indonesia requires new innovations to facilitate the process. One of them is by using a more practical technology in the form of Automatic measuring machine of mass and dimension.

The automatic measuring machine of mass and dimension is a machine that can retrieve information in the form of the mass and dimensions of irregular-shaped objects. The working principle of this tool is the incorporation of the principles of action of a machine called machine vision coupled with other components in the form of a load cell to measure the masses on an object. Machine vision is a machine that can take information from imagery or digital images automatically, which is used to control quality. Its use is increasing in manufacturing industries to replace human labour inspection. Machine vision is required to repeat the inspections in such a short time because of faster, more objective, and can work in a continue (Cognex, 2016). The system of machine vision works using software and other supporting tools, such as Matlab software, and hardware such as Arduino.

Based on the above question, the idea emerged for designing of automatic measuring machine of mass and dimension using the DFMA (Design for Manufacture and Assembly) method approach.

2.0 LITERATURE REVIEW

2.1 The Design From The Perspective of Structure

Based on the form of its object, the design can be divided into three (Epsito and R.J. Thrower., 1991). The first is the original design, that is the design of the invention that really is based on the discovery that hasn't been there before. The second is development or modification, that is the development of existing products in order to increase efficiency, effectiveness, or competitiveness to meet the demands of the market or the demands of the times. The third is the adoption of the design is namely taking part or system entirely from existing products for other uses, in other words, to bring about machine tool which has another function.

2.2 Design of User Perspective

The first step in the design stage is to determine the needs of users, and then create a specification that can meet the requirements, and then determine the functional level, i.e. the level where things are needed as well as the form of the system represented in general without mentioning about the realization of the concept as well as its physical (Hatamura, y. Yamamoto, y. and 1999). Then switch to the conceptual level, i.e. the level where systems have been modeled based on the principles of a possible solution to meet the design requirements. The last step is a component level, i.e. the level where systems have been modeled with specific physical characteristics that can embody the concept and design requirements.

2.3 Automatic Machine Measuring of Mass and Dimension

Automatic machine measuring of mass and dimension is a machine that consists of several components that are functioning as retrieval of information in the form of mass (kg) and dimensions (m^3) of a irregular shaped objects. The working principle of Automatic measuring machine of mass and dimension this is by reading the information given the mass of the load cell, simultaneously the camera will do the shooting from reflection of light given by the sensor beam moving together/in line with a camera and laser triangular method by using image measurement of 2D image, then from a 2D image already taken will be processed using computer algorithms to get the 3D image to determine the volume of the object. Basic principles for determining the dimensions of an object as measured using exactly the same working principles of a machine called machine vision.

Machine vision is a system consisting of hardware and software. Machine vision systems rely heavily on digital sensor in the camera industry (machine vision camera) using some optical Machine vision has several functions, among others:

1. Machine vision System is used to identify the component and read the barcode ID code matrix (2D) and mark directly on an object in the letter also printed letters on components, labels, and packages. This system also identifies the components or parts of an object by obtaining places (knowing) the location pattern uniquely identifies objects by color, shape, size.
2. Machine vision can also measure the distance between two or more points, or the geometry on an object and determine whether these measurements meet specifications. If no object is denied of the sort, usually a camera placed at a fixed position recording.
3. Machine vision is used to inspect the object of a standard for example there are defects in the fruit, defects in a spare part in the production of beverages, level should be on the bottle.2.4 Design for Manufacturing and Assembly (DFMA).

2.3.1 Definition of DFMA

Design for manufacturing and assembly (DFMA) is defined as the design of a product or component that can simplify the process of manufacturing, and the Assembly process with other components to become a unified product. If interpreted independently, DFMA is a design of a product or component which can facilitate and ease the process of Assembly with other components. Or in other words a designer should think about whether the product design process can facilitate assembly he made later. It can even provide an alternative design of other products in achieving product quality, life cycle and low production costs.

Design for manufacturing and Assembly (DFMA) is a management tool and software developed from the premise that about 70% of all costs of the development, production and Assembly are determined during the product design phase. DFMA allows designers to consider the issue of the selection of materials and the manufacturing process at the beginning of the design. (Joseph, 1992).

2.3.2 Mass Measuring Instruments

Mass measurement tool is an instrument or a tool to use to calculate the magnitude of mass, these measurements are usually done in units of kilograms (kg). An example of measuring

instrument mass is spring-loaded balance thirsty scales and balances, seated. A day in the life – today we very often use tools to measure mass, for example, is currently on the market are traders using the scales for measuring mass. But the mistake that is often made is to say that even though the weight in the measure is the mass of the object, because the weight is not equal to the mass of the (different). So, with the scales of the traders can determine how the mass of an object.

2.4 Major Components of Mass and Volume Measuring Instruments at Automatic Measuring Machine of Mass and Dimension

The following are the main components of the mass and volume measuring device on the automatic measuring machine of mass and dimension:

2.4.1 Framework

The framework is a structure that consists of a number of rods which are attached to each other at the end with the connection-connection, so as to form a solid frame. The framework serves as the anchoring and place put the components of machines to be made. In the construction of mass measuring device on the automatic machine mechine measure mass and dimension it will use aluminium frame with the dimensions 20 x 20 mm frame cross section as shown in the figure 1 below:

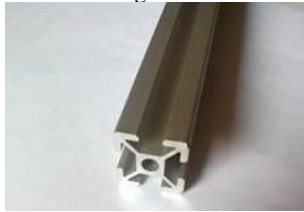

Figure 1: Aluminium profile

2.4.2 Load Cell

Defenisi Weight Sensors (Load cell) Load cell sensor is designed to detect the pressure or the weight of a load, the measurements performed by the load cell using the principle of pressure (AmericaModule H: 2010). Load cell widely used in industries that require equipment to measure the mass (Piskorowski et.al., 2008). In General, load cell and sensor styles contain a spring (spring) the metal mechanic with applying some of the metal foil strain gauges (SG). Spring-loaded mechanical strains from appearing as the effects of the imposition of which is then transmitted on strain gauges. Measurement of the signal resulting from the load cell is from changes in the resistance of the strain gauge, which is linear with the force applied (Mauselein et.al, 2009).

Load cell used in this final project is load cell with a maximum load capacity of 50 kg.



Figure 2: Load cell (www.rajaloadcell.com).

2.4.3 Stepper Motor

Motor stepper is a device that makes use of the Activator magnet pull style. rotors stop on the pole position be excited by the current flow in the coil. The rotor on the motor usually rotates continuously if the motor be excited, but the rotors on motor stepper turn out from a position of silence by changing excitation poles.

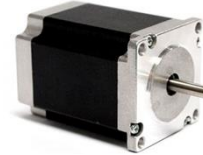

Figure 3: Motor Stepper (Susa'at, S. 2015)

2.4.4 Power Supply

Power supply is an electronic tool that is useful for other pirantii, especially electrical power (Wikipedia). Basically the power supply is not a device that produces electrical energy, but there are some power supply which produces mechanical energy, and the energy of the other. The workings of power supply AC voltage change voltage DC becomes smaller with the help of a transformer. This voltage is then submitted with circuit rectifier voltage, and in the end added condenser as the final voltage of DC voltage so generated by the power supply is not wavy.



Figure 4: Power supply

2.4.5 Laser

Laser is a tool that can increase the intensity of the directional light generated by high light intensity in a particular wave ranges. The word is derived from the acronym laser (Light Amplification by Stimulated emission of radiation) which means the occurrence of reinforcement of the light by the emission of radiation stimulated. The light emitted from the laser stimulation produced by the emission of radiation from the medium that is in the laser (Amir,2014). The principle of laser invented by Einstein since 1917, until recently a laser has been growing rapidly in a variety of applications. Power laser generated can range from the nanowatt to thousands of Watts (1021 w).



Figure 5: Laser line

2.4.6 Camera

The camera is to acquire a digital image. Digital image captured by the camera can be processed until it brings many of the parameters required by the robot control systems, including the parameters of the position, shape, and paraeter parameters of speed. The camera is a tool for catching the waves of light

reflected by the object, so the object can be mapped in the form of image on a digital camera image generated is s images in digital form. Generally a digital camera consists of a lens, light sensor, and digitizer as shown in.



Figure 6: Camera Cmos

2.4.7 Arduino

Arduino is an electronic circuit that is open source, and have hardware and software that is easy to use. The Arduino can recognize the surrounding environment through various types of sensors and can control lights, motors, and other actuators of various types. Arduino has many types, such as the Arduino Uno, Arduino Mega 2560, Arduino Fio, and others (www.arduino.cc).



Figure 7: Arduino Uno

3.0 METHODOLOGY

3.1 Machining Flowchart

The following will explain how the stages in making mass automated gauges on automatic measuring machine of mass and dimension, so this tool later can work in accordance with the expectations of the desired.

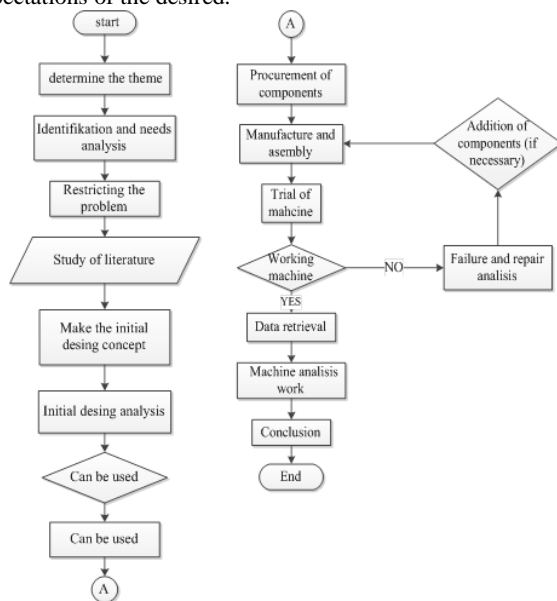

Figure 8: The research procedure

3.2 Stages of Workmanship

The research procedure in figure 8 can be explained through the stages of work as follows:

1. Determine theme design
The main thing barus determined was the theme of the draft is to be made. In designing this time epochs is the design of the automatic measuring instrument of mass on automatic measuring machine of mass and dimension.
2. Identification and analysis of needs
A tool will be created should have the following criteria:
 - a. Easy to use.
 - b. Hold the burden of at least 50 kg.
 - c. Are simple and attractive.
 - d. Easy Assembly and maintenance.
3. Demarcation problems
Tool created its capacity was restricted to objects that have the length, width and height (50 x 50 x 50) cm and has a size of 50 kg maximum weight.
4. The study of literature.
Study of literature is used to understand the basics of the theory that deals with the measurement system, so it is expected to give an overview of design in making mass automated gauges on automatic measuring machine of mass and This dimension.
5. Create the initial design concept
Any thoughts or ideas that are used for the initial design.
6. Analysis of the Initial design
From the initial design which has been made, analyzed to find out the possibilities that will occur when a possible illicit manufacture of tools, whether it could be used, what are the barriers are, how to cope with it, then the alternative is to be used.
7. Make the final design
Is a design that was already considered the most mungin for design in the manufacture of tools.
8. Procurement of components
It is the time to set up the components that are not yet available.
9. Manufacture and assembly tools
After all the components are readily available, then carried out the process of manufacture and Assembly. This process usually takes quite a long time.
10. Trial tools
Trial is testing tool to the tools that are already assembled. Is it already meets the desire or not.
11. Analysis of failure and corrective actions
This is done if the results obtained from testing this tool is not as desired. Do the addition of components when necessary to obtain satisfactory results. When adding a component then returns to the process of making and assembling tool.
12. Data retrieval
Data retrieval is performed after the tool has been made in accordance with the desired.
13. Performance analysis tool
Of the data that is already taken, then we can analyze tool that is already made. What is the tool created already works fine.
14. Conclusion
After the analysis is obtained based on the data obtained, then it will get a conclusion about the tools that are already

completed. Determine theme design

The main thing barus determined was the theme of the draft is to be made. In designing this time epochs is the design of the automatic measuring instrument of mass on automatic measuring machine of mass and dimension.

3.3 Tools And Materials

The tools and materials used in the manufacture of automatic measuring machine of mass and this dimension can be seen in Table 1.

Table 1: The tools and materials

No	Tools	Matrials
1	Camera	Logistic packages with different mass and dimension.
2	Laser	
3	Arduino	
4	Motor stepper	
5	Motor Driver	
6	Load Cell	
7	Aluminum Frame	
8	Power Supply	

3.4 Basic Principles of Mass Automatic Gauges on Automatic Measuring Machine of Mass and Dimension.

The working principle of automatic mass measuring instruments at automatic measuring machine of mass and dimension can be seen in the following image:

1. The Object to be measured is placed above the base objects.
2. Arduino gave orders to the motor driver.
3. Current from the AC is converted to DC power supply for use switch on the motor driver.
4. Motor driver delivers orders to motor 1 to move the sliding shaft that has been associated with a camera and laser.
5. Once the sliding shaft is moving, then the camera and the laser do figure to get the data recording volume, simultaneously load cell do the heavy data retrieval.
6. Data that has been obtained is transferred to matlab software to be processed.
7. Once all of the data obtained, the arduino will give the command to the driver of the motor to drive the motor 2.
8. AC convert to DC using the power supply.

Motor driver delivers orders to motor 2 which is already linked with the axis screw. When the axis of the screw driving then rotate objects already connected by screw axis with bolt system will do the work in the form of the movement pushing objects already measured through roller storage place of entry, then the impeller will be back originally.

4.0 RESULTS AND DISCUSSION

4.1 The Design Tool

The process of designing a product or goods have an important role in defining the physical form of a product. In the process of designing the DFMA (Design For Manufacture and Assembly) has the stages that must be traversed, from design concept to production (manufacture of tools).

4.2 Matrix Marfologi

Morphological matrix used to determine alternatives a concept product that can eventually be developed into a product. The form

of matrix morphology in determining alternatives concept products shown in the table 2.

Table 2: Form a morphological matrix in determining product concept alternatives

Function	The Sub Function	Sub-Sub Function
1. The Mechanism of Rotation of Motor	1.1 Electric	1.1.a DC Electric Motor
2. Transmission Mechanism	2.1 Transmission Gears	2.1.a Gears
	2.2 Transmission of Screw Conveyor	2.2.a Screw Shaft
3. Loading Mechanism	3.1 Load Cell	3.1.a <i>Load Cell Capacity 50 kg.</i> 3.1.b Load cell Capacity 100 kg.
4. The Mechanism of The Order	4.1 Type Of Order	4.1.a Holo Steel (Order)
	4.2 Cradle Load Cell	4.1.b Aluminum (can be uninstalled) 4.2. a Fused with the main frame 4.2. b Separate from the main frame
5. The Mechanism of The Base Objects	5.1 Wear layered plate retaining Order thin	5.1.a Holo steel 5.1. b Order steel plate thick 3 mm
	5.2 Wear Plate	5.2. a Plate Duralium thick 12 mm
6. Speed Regulator Mechanism	6.1 Setting	6.1.a Arduino
7. Regulatory mechanism of Laser and camera angle	7.1 Camera	7.1.a Angle 45° 7.1. b Angle 90°
	7.2 Laser	7.2. a Angle 45° 7.2. b Angle 90°
8. Test Specimens	8.1 <i>Parcel Logistics</i>	8.1.a Irregular shape

Description of the table above are as follows:

1. Mechanism of rotation of Motor
The mechanism of rotation of the motor is a mechanism that serves to regulate the speed of the round before it is transmitted. The system of rotation of the motor as a driving force transmission system using DC electric motors namely motor stepper. Stepper Motors are used in this design are positioned with the direction of the spin which can be clockwise then counterclockwise rotation with the goal of getting movement back and forth (star-end-star) which will then be transmitted through transmission gear or screw conveyor.
2. Transmission Mechanisms
The transmission mechanism is affected by the speed of rotation of DC motors which rotate speed in DC motor will be transmitted via the transmission gears for the transmission system on the shuttle or leverage system screw conveyor system for thrust.
3. Loading Mechanism
Loading mechanism is a system used to measure the mass in the given loading. Measuring instruments used is the digital scales in the form of load cell. The capacity of the load cell used berfariasi, including load cell capacity 100 kg and 50 kg.

4. Mechanism of the Order

The mechanism of the order selected on the basis of the needs of the needed tools. The selection of the order can be done based on several considerations such as the type of material, the form of order, prices and functions of order. The selection is based upon the manufacturing process time and ease the Assembly process.

5. Mechanism of the Base Objects

The mechanism of the base object is selected based on the resistance to the imposition of the will be given and the given emphasis style align with the goals of the reading on the sensor load cell. The design on the pedestal it had several design alternatives such as the use of cantilever frame of thin plate by placing the above order and only with the use of plate material with duralium approx 12 mm.

6. Speed Control Mechanism

Speed regulator used on motor stepper is the arduino. Arduino is used to control the speed of rotation of motor stepper.

7. Mechanism of Laser Angle Control

The laser is used for the measuring system of the marker on the volume. Setting the quantity of laser angle required for the sake of getting the perfect image on the object of measurement for the perfection of the data to be retrieved.

8. Test Specimen

Specimen test on automatic measuring machine of mass and dimension is still in the form of objects that the shape is still irregular. The test specimens are used delivery package logistics town.

Laser tilt angle control regulated amounted to 90° (perpendicular) while the slope of 45° rec. The measuring object to be measured is irregular objects box logistics package. The form of the development of the concept of the first product shown in the figure 9.

The development of concept design 2

Concept 2 = 1.1. a + 2.2. a + 3.1. a + 4.1. b + 5.1. b + a + 6.1.7.1.7.2. a + b + a 8.1.

This brings the concept of operation of the tool by using electrical energy as a source of mechanical energy. Transmission system on a system for measuring the volume and driving system of measuring objects to the repository using the screw conveyor system. The transmission from the motor to spin the screw shaft is transmitted with the addition of the clutch between the motor with the screw shaft.

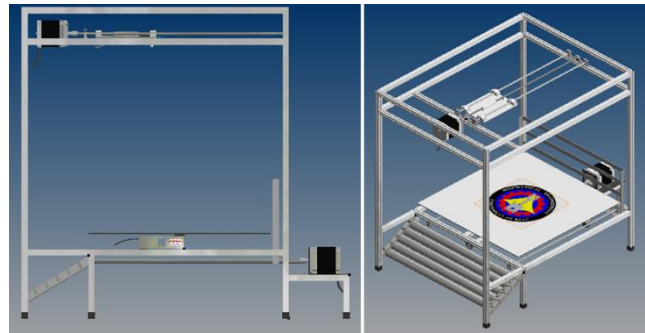

Figure 10: The second design

4.3 Design Concept

A. The concept of product development

In designing the tool automatic measuring machine of mass and dimension it created multiple design alternatives as outlined below:

The development of concept design 1

Concept 1 = 1.1. a + a + 2.1 2.2. a + 3.1. a + a + 4.1.5.1. a + a + 6.1.7.1.7.2. a + b + a 8.1.

The mechanism of the main frame on this design using the holo-steel with dimensions 20 mm x 20 mm with a thickness of 1 mm as the main frame. On the base of objects, this concept using the base objects by using a cantilever frame with steel materials holo (similar to the concept of main-frame) and then coated with a thin aluminum plate material on it.

The mechanism of the main frame on the design using an aluminum frame with the dimensions 20 mm x 20 mm as the main frame. The pedestal design objects using frame 3 mm thick steel plate which is coated with a thin aluminum plate on top of it. Laser tilt angle control regulated amounted to 90° (perpendicular) while the slope of 45° rec. The measuring object to be measured is irregular objects box logistics package. The form of the development of the concept of a second product shown in the figure 10.

The development of concept design 3

Concept 3 = 1.1. a + 2.2. a + 3.1. a + 4.1.4.2. b + b + a + 5.2.6.1. a + 7.1.7.2. b + a + a 8.1.

This brings the concept of operation of the tool by using electrical energy as a source of mechanical energy. Transmission system on a system for measuring the volume and driving system of measuring objects to the repository using the screw conveyor system. The transmission from the motor to spin the screw shaft is transmitted with the addition of the clutch between the motor with the screw shaft. The mechanism of the main frame on the design using an aluminum frame with the dimensions 20 mm x 20 mm as the main frame. For load cell mounting mechanism, added a table with the different order types. This type of order on a table stand the load cell uses a steel frame with the dimensions length holo 35 mm x 15 mm with a thickness of 12 mm. The addition of these tables with the aim of reducing the load styles, and vibrations occur which are caused by the rotation of the motor and the system the driving force was at work against the main

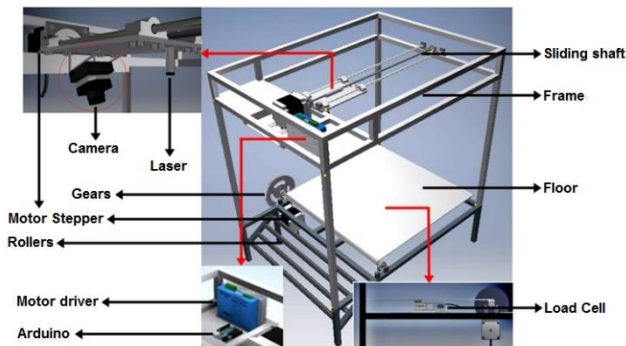

Figure 9: The first design

bermaterialkan aluminium frame. The pedestal design objects using a cantilever frame, without using the base object is created by using a license plate with a thickness of 12 mm duralium are directly linked with the sensor on the load cell. Laser tilt angle

control regulated amounted to 45° slope while his camera of 90° (perpendicular). The measuring object to be measured is irregular objects box logistics package. The form of the development of the concept of a third product is shown in the following figure 11.

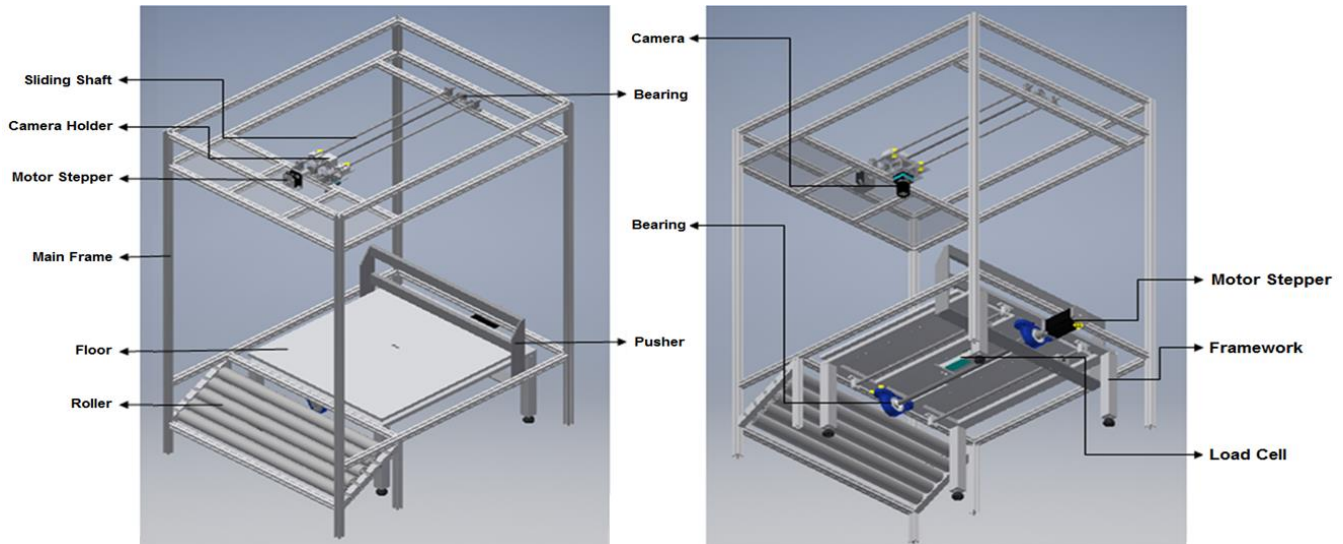

Figure 11: The final design

B. Automatic Machine Components Measuring the Identification of Mass and Dimension

Based on the deliberations undertaken with reference to DFMA method, then the design concept was selected for the 3 final design at the research and for the subsequent manufacturing process is done. As for the components of Automatic Measuring Machine of Mass and Dimension on this final design described as shown below:

Table 3:

Ref.No.	Description	Qty	Function
1	Main Frame	1	As main housing of all parts
2	Roller	5	As the successor to the object where it is stored
3	Motor Stepper 1	1	As a screw shaft player that will move the camera holder
4	Motor Stepper 2	1	As a screw shaft player that will move support
5	Motor Driver	1	Function to communicate between the controller and actuator and strengthen the signal from the controller
6	Arduino	1	As the brain of the machine vision component
7	Power supply	1	As a modifier of AC current to DC
8	Load Cell	1	Serves as a tool to measure mass
9	Camera	1	Serves as a tool for shooting
10	Laser	1	Serves as a file provider for taking height data objects

Analysis for DFA and DFM on Automatic Machine components Measuring of Mass and Dimension.

Table 4 :

No	Function	Advantages	Deficiency
1	Aluminum frame	<ul style="list-style-type: none"> Lightweight Attractive display 	<ul style="list-style-type: none"> The price is more expensive Load resistance
2	The main frame assembly system uses a joint L	<ul style="list-style-type: none"> Can / easily be assembled Does not damage other matrices during the assembly process 	<ul style="list-style-type: none"> The strength of the connection is less sturdy
3	Use of the support system	<ul style="list-style-type: none"> Can push loads with a maximum capacity of 50 kg 	<ul style="list-style-type: none"> The form of big and legal drivers takes place

5.0 CONCLUSION

Some of the conclusions that can be written from automatic measuring machine of mass and dimension are as follows:

1. The design of the automatic machine dimensions machine measure of mass and dimension it is the result of the analysis and survey of the process of measurement on service delivery. Automatic machine dimensions machine measuring of mass and dimension are 880 mm x 660 mm x 1220 mm. machine Frame made from aluminum profile measuring 20 mm x 20 mm. casing Materials using acrylic material with a thickness of 5 mm. The system used is the transmission shaft screw and sliding shafts. The shaft of the screw being used there are two pieces that are each 1 sized shaft diameter 8 mm and 16 mm shaft size 2. sliding shafts used there are 4 pieces that each have a size 2 size diameter 8 mm for cameras and 2

measuring 12 mm to drivers of goods.

2. Capacity of objects that could in the measure, with a maximum size of 50 cm long x 50 cm wide x 50 cm high and maximum weight of 50 kg and load cell is reduced by the weight of the plinth duralium more or less maximum kg 40 kg.

ACKNOWLEDGEMENTS

The authors sincerely acknowledge and thank the Directorate General of Strengthening Research and Development, the Ministry of Research, Technology and Higher Education who supports this research with Kompetitif Nasional (National Competitive) program in Indonesia 2018.

REFERENCE

1. Boothroyd, G. Dewhurst, P. Knight, W. 2011. Product design for manufacture and assembly. Third Edition. Taylor & Francis Group. USA
2. Cognex. 2016. Introduction to Machine Vision. Company booklet USA www.cognex.com
3. Constance, Joseph. 1992. DFMA: Learn to Design for Manufacture and Assembly. Eight Edition. Mechanical Engineering-CIME.
4. Respatindo, A.S PT. 2012. (accessed on June 6, 2017). Cara perhitungan berat dalam pengiriman barang, www.respatindo.com.
5. Ashok, W. R., W. S. Panse, and H. Apte. 2015. Laser Treeangulation Based Object Height Measurement. International Journal For Research In Emerging Science And Technology, Vol 2:1 November 23, 2015.
6. Chairuddin, I, Eka M. 2016. Strategi bisnis PT. POS Indonesia. Jurnal Manajemen Bisnis Transportasi Dan Logistik. 2. (1):343-325.
7. Arief D S, Fitra E, Minarni, Herman, Salambue R. 2018. Modeling of Control System on Sorting Palm Fruit Machine by Using Arduino Microcontroller. Journal of Ocean, Mechanical and Aerospace - Science and Engineering-, Vol.52 February 30, 2018.
8. A. Hamzah, Arief, D S., G. L. Sihombing, and Andri. 2017. Automatic Control System Design of the Threshing Station Model, Case Study in PT. Perkebunan Nusantara V - PKS Sei Galuh. Journal of Ocean, Mechanical and Aerospace -Science and Engineering-, Vol.45 July 30, 2017.
9. Cognex. 2016. Introduction to Machine Vision. Company booklet. USA www.cognex.com
10. Prawoto, Ihsan. July 2015. Pengetian Arduino UNO Mikrokontroler ATmega328. <http://www.caratekno.com/2015/07/pengertianarduino-uno-kontroler.html>. (accessed on August 28, 2018)
11. Chen, F., Brown G.M., Song M. 2000. Overview of three-dimensional shape measurement using optical methods. Opt. Eng. 39:10-22.