

Study on Subsea Petroleum Pipeline Design in Deepwater

Abd Khair Junaidi,^a and Jaswar Koto,^{a,b,*}

^a*Department of Aeronautics, Automotive and Ocean Engineering, Mechanical Engineering, Universiti Teknologi Malaysia, Malaysia*

^b*Ocean and Aerospace Research Institute, Indonesia*

*Corresponding author: jaswar.koto@gmail.com

Paper History

Received: 25-October-2014

Accepted: 13-November-2014

ABSTRACT

Developments of offshore pipeline projects in Malaysia waters are showing general trend towards deeper water, such as KIKEH in 2200 meter water depth. As the exploration is getting into deeper water or crossing a deep water section. The different design issues may become governing compared to shallow water. Several number of issues are needed to be taken onto account in the design of pipelines in deep water such as aspect related to high external pressure, limitation for installation and geo-hazards are addressed. In order to give an early insight for designer to measure the reliability for a deep water project to current technology capabilities, a simulation program is required to achieve the objective.

KEYWORDS: *Design; Deep Water; Subsea Pipeline.*

1.0 INTRODUCTION

Demands on petroleum as the main source of energy with the maturity of established oil reserved in onshore and shallow water has influenced for many oil and gas companies to extend their operation further into deep water as fact that most shallow water oil basin has been almost fully utilized. As a result of this shifting of offshore oil and gas production further away from shore, the pipelines have to be laid in deeper waters and over longer distances. During last 30 years, significant reserves have been located offshore in places like North Sea, the Gulf of Mexico, the Persian Gulf, offshore Brazil, West Africa, Malaysia, Indonesia, Northwest, Australia and other places.

In this study we will discuss on conceptual design for deep water. Design issues associated with deep water pipelines are pressure containment, hydrostatic collapse, local buckling, propagation buckling, on-bottom stability, plastic strain limits, free spanning as well as fatigue and fracture aspects. The effects of fabrication tolerances such as ovalisation and wall thickness variation on hydrostatic collapse and the design of buckle arrestors also need to be considered. Manufacturing capabilities for large diameter pipe also taking consider design reliability.

2.0 LITERATURE REVIEW

The ocean covers 70% of our planet and is a huge bank of energy waiting to be extracted. This makes the prospect of the ocean as an alternative energy source immense. Marine renewable energy comes in various forms, namely ocean thermal gradient, tidal range, ocean currents, ocean waves and ocean salinity gradient. For each form, there are a number of ways to convert the energy into a useful form such as electricity.

2.1 Hydrostatic Collapse Pressure Buckling

Pipeline wall thickness design is one of the most critical design considerations that have to be done before pipeline construction. This will affect the pipes resistance against internal- and external pressure, the allowed corrosion, and the influence of longitudinal stress, bending and indentation, as well as the cost aspect.

As the pipeline is installed deeper into the sea by lay barge, the pipelines are typically subjected to external pressure due to hydrodynamic pressure. The pipelines are designed to withstand external pressure at possibility when there is no fluid in pipeline (no internal pressure). This differential pressure between external and internal pressure acting on the pipe wall due to hydrostatic head can cause pipe to collapse.

The collapse pressure predicted by these formulas should be compared to the hydrostatic pressure due to pipeline depth at seabed, in order to choose the most adequate and feasible diameter and wall thickness for particular range of depth.

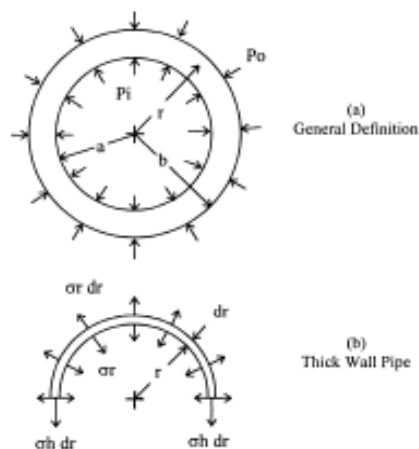

Fig.1 Pressurized Pipe System [2].

2.2 Buckle Propagation

A buckle resulting from excessive bending during installation or any other cause may propagate along the pipe due to presence of hydrostatic pressure by the seawater acting on the pipeline. For deep water pipelines, since the hydrostatic pressure is the major force that cause failure mode of pipeline, it is essential to estimate buckle propagation. Buckle arrestors may be used to stop such propagating buckles by confining a buckle/collapse failure to the interval between arrestors. Buckle arrestors may be designed as devices attached to or welded to the pipe or they may be joints of thicker pipe. Buckle arrestors will normally be spaced at suitable intervals along the pipeline for water depths where the external pressure exceeds the propagating pressure level. The following are types of buckle arrestors;

- Integral Thick Wall Arrestors which consist of suitable length of thick walled joints.
- Integral Ring Arrestors which comprise forged or machined rings that are welded in between pipe joints.

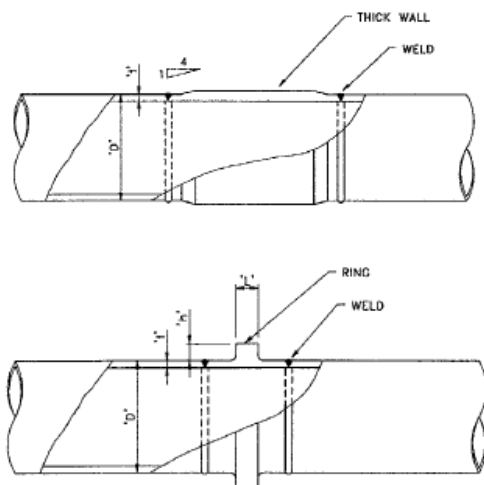

Fig.2 Integral Thick Wall and Integral Ring Type Buckle Arrestors [3].

2.3 Pipe-laying Limitation

In recent years, offshore oil and gas exploration and production activities have increased dramatically in deep waters. The offshore pipelines have to be laid to the seabed of corresponding water depth to gathering and transporting the products. The safety of offshore pipelines in complicated loading conditions such as high ambient pressure, axial tension and bending moment during deep water installation has drawn more attentions than shallow waters.

There are two common methods applied for installing offshore pipelines;

- S-Lay
- J-Lay

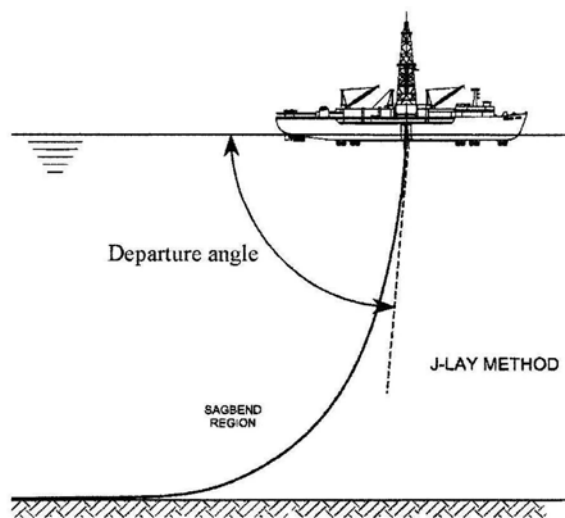

Figure 3: Schematic of J-Lay method for pipe laying.

J-Lay is one of method applied for deep water pipeline installation. As name implies, J-Lay laid the pipeline from the vessel nearly vertical position forming characteristic of J-shape. The J like shape of the pipeline segment during installation has been found to have advantages for laying deep waters, as there is no over bend region (only sag bend at lower curvature) and less tension required than for the S-Lay.

2.4 Geo-Hazards for Route Selection

Ultra deep water routes descend the continental slope into water depth in excess of 2000m. These slope areas are the main paths of sediment transfer from the continental shelves to the deep ocean basin. Hazard that can impact on the pipeline originate from fault rupture and slope failures that may cause long term processes such as landslides, turbidity flow and gravity flow, soil liquefaction and combination of these events.

Free span can result in failure of pipelines due to excessive yielding and fatigue. It may also cause interference with human activities such as fishing. Free span can occur due to unsupported

weight of the pipeline section and dynamic loads from waves and currents. When a fluid flows across a pipeline the flow separates, vortices are shed and periodic wake is formed. Each time a vortex is shed it alters the local pressure distribution and the pipeline experiences a time-varying force at the frequency of vortex shedding. Under resonant conditions, sustained oscillations can be excited and the pipeline can eventually lead to catastrophic failure. The oscillations are normally in-line with the flow direction but can be transverse (cross-flow) depending on current velocity and span length.

3.0 METHODOLOGY

In this study, a simulation program that functioned to perform FEED design for pipeline is developed using Microsoft Visual Studio 2012. The algorithm used in this program is based on classification standards such as DNV, API and ABS. The program also verified based on published journal and design reports. The following are steps in methodology.

- Identify problem statement, objectives and literature review.
- Discuss challenges involves for deep water pipeline design.
- Code development (C-Deep) and perform simulation based on case study on wall thickness selection, buckle arrestor design and free spanning and installation configuration
- Results, Discussion and Conclusion

3.1 Code Development for Conceptual Design

Microsoft Visual Basic 2012 was selected as the main tools in orders to develop the simulation program. Microsoft Visual Studio is an integrated development environment (IDE) from Microsoft. It is used to develop console and graphical user interface application along with Windows Forms which is making it very user friendly to the programmer as well to the program user compared to others code developer program such as Fortran and Matlab which required the users to understand at least few commands to run the codes.

Table 1: Pipeline Design Simulation Program Developed (C-Deep).

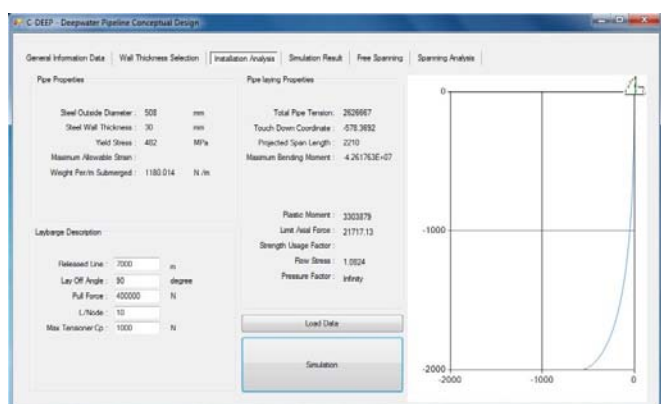

3.2 Programming Flow Chart

Before developing the simulation program, a programming flow chart was outlined systematically in order to achieve the objectives of this study. This step is very essential for any code development works as its provide a systematic and clear on flow of the program as well to prevent any unhandled exception due to unstructured flow.

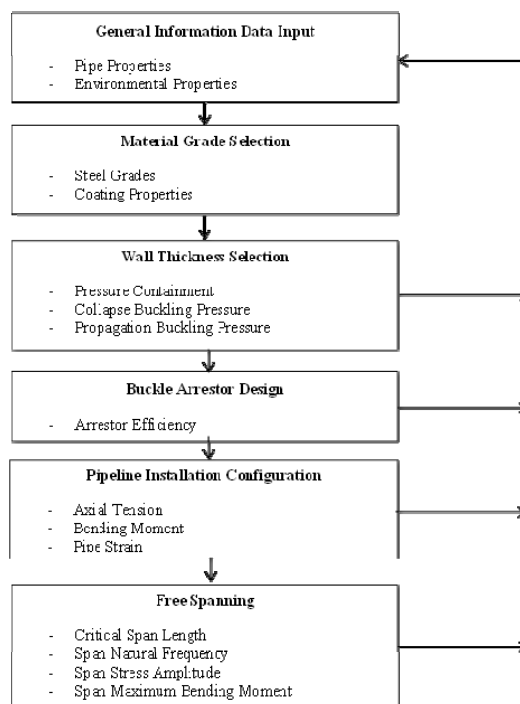

Figure 4: Programming Flow Chart for the Overall Simulation Program

4.0 RESULTS AND DISCUSSION

4.1 Wall Thickness Selection

Wall thickness selection due to collapse buckling pressure is obtained by using three different high strength steel grades namely X60, X65 and X70. The output of collapse pressure obtained from the simulation and plotted as show in Figure.5. By using higher strength steel grade has a higher effect on wall thickness requirements especially for deeper water compared to shallow water. Wall thickness generally will affect both cost and weight and by using higher steel grade these both parameters can be greatly reduced especially when involving high external pressure. Wall thickness reduction as a result of increased steel grades is depending of pipe diameter when using pipe collapse requirement. The percentage increment of collapse pressure among the steel grades is increasing to respective wall thickness.

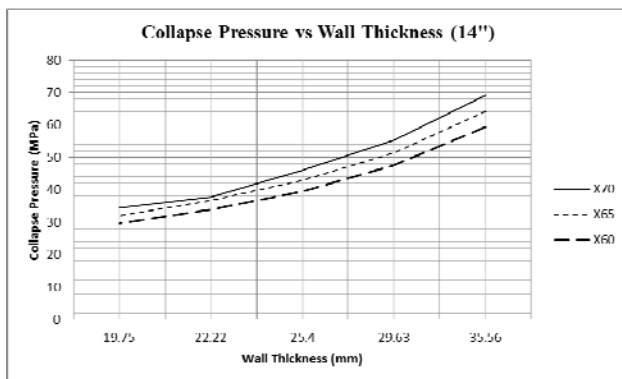

Figure 5: 14'' Pipe: Wall Thickness against Steel Grade.

4.2 Buckle Arrestor Design

Integral ring arrestor is used in this study as it is known for its good efficiency buckle arrestors by most. These arrestors directly increase wall strength by welding it to pipe and hereby increasing thickness of one section of pipe. The plotted results for the arrestor efficiency show in Figure.6. From Figure.6 we observe that the arrestor efficiency can be increased significantly by increasing its thickness. Therefore, we can conclude that arrestor efficiency is greatly affected by increasing thickness compared to length.

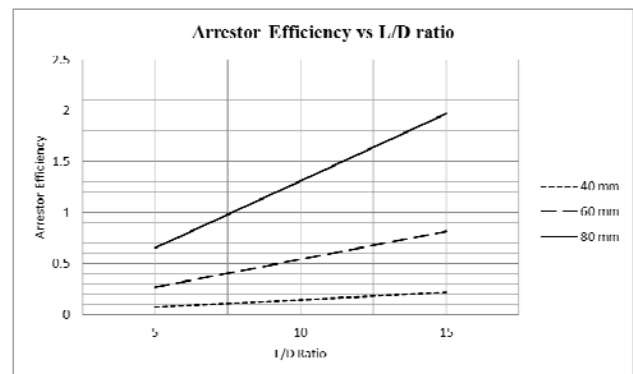

Figure 6: Integral Arrestor Efficiency versus L/D ratio of Buckle Arrestor.

4.3 Installation Configuration

The results obtained from static installation analysis for J-Lay from the simulation program based on general information data input. Results presented in the following are provided to prove lay ability of the given pipelines with existing lay vessels as shown in Table.2. The installation configuration for 90° was setup with 400kN horizontal force as shown in Figure.7. The result from the simulation is based on simple catenary equation not including flexural stiffness on sag bend. The seabed is assumed as rigid and plane and no hydrodynamic loads acting on the pipe with water depth of 2000 meter. The following conclusion were achieved,

- Top tension required for pipeline installation were found to be within the tension capacities of existing vessels at 2000 meter water depths.
- Sag bend bending moment were inside the allowable bending moments at 2000 meter water depth
- Departure angles required are within the vessels ability

Table 2: J-Lay Pipe Installation Results

Lay-off angle	Horizontal Pull Force (kN)	Projected Span length (m)	Touchdown point along axis from vessel (m)	Top tension load (kN)	Sag bend bending moment (kNm)
80	400	2360	978	2639.5	372004
90	400	2260	602	2529.80	370260
90	1000	2310	830	2742.32	314019

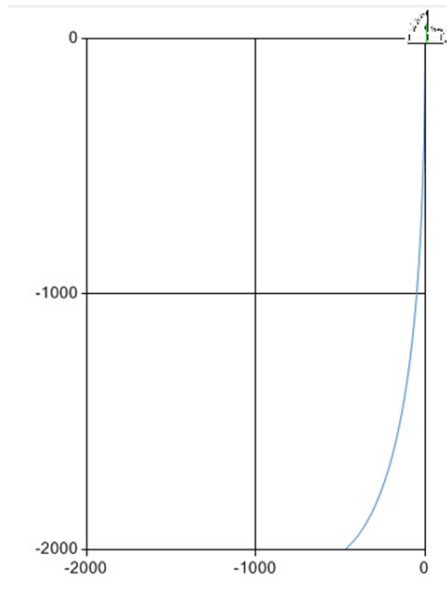

Figure 7: Static Pipe-Lay Configuration for (a) 90 degree angle 400 kN force.

4.4 Free Spanning

The results obtained from the free spanning section of the simulation program. The simulation is based on 20" diameter pipeline with 25.4 mm wall thickness. The pipe weight is based on flooded condition which is the most risky condition for free span. The plotted results obtained as shown in Figure.8

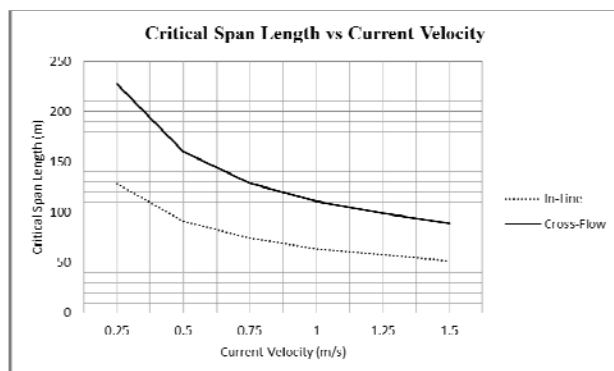

Figure 8: Graph for the Critical Span Length against the Current Velocity.

5.0 CONCLUSION

As conclusion from this study, numbers of issues associated in designing deep-water pipeline are was delivered in this paper and to put into application a simulation program was developed that

function to perform preliminary design for deep water pipeline. The program developed was verified based on published journals and a simulation based on case study was performed.

ACKNOWLEDGMENTS

The authors are very grateful to Universiti Teknologi Malaysia and Ocean and Aerospace Research Institute, Indonesia for supporting this study.

REFERENCES

1. Det Norske Veritas, DNV 2007, Offshore standard DNV-OS-F101, Submarine Pipeline Systems, Hovik Norwat, Det Norske Veritas, DNV
2. API Recommended Practice 1111 (1999) 'Design, Construction, Operation, and Maintenance of Offshore Hydrocarbon Pipelines (Limit State Design)', American Petroleum Institute.
3. S. Braskoro, T.D.T. Dronkers, M. van Driel (2004). From Shallow to Deep: Implications for Offshore Pipeline Design. Journal of the Indonesian Oil and Gas Community, pp.1-9, 2004
4. Mohd Nazree Mohmed. Design, Fabrication and Testing of Wave Energy Float. B. Eng. Thesis. Universiti Teknologi Malaysia; 2009
5. T. Sriskandarajah, P. Ragupathy, G. Anurudran and R. Wilkins (2001), Design and Installation Aspects in the Use of High Strength Steels for Deep and Ultra-Deep water Pipelines, The International Society of Offshore and Polar Engineers, 2001
6. Yong Bai, Ragnar 19land and Torgeir Moan(1992), Collapse of Thick Tubes Under Pressure, Tension, Bending and Their Combinations, The International Society of Offshore and Polar Engineers (1992) Heights Data in South China Sea ", International Conference on Marine Technology MTP-21
7. T.G Johns, R.E Nesloh and J.E Sorenson (1976), Propagating Buckle Arrestors for Offshore Pipelines, Battelle Columbus Laboratories (1980)
8. S.A Karamanos and J.L Tassoulas (1991) Stability of Deep water Pipelines Under Combined Loading, 1991
9. Z.G Li (2010), Configuration of Submarine Pipeline for Deep water S-Lay Technique, The International Society of Offshore and Polar Engineers (ISOPE)(2010)
10. Guarracino, F. V., Mallardo (1999), "A refined analysis of submerged pipelines in seabed laying", Applied Ocean Research, vol. 21, 1999.